

ALSET LIGHTNING SHIELD SYSTEM



Innovative Solutions for Your High Integrity Power Needs



RedHawk Energy Systems, LLC
10340 Palmer Rd., S.W.
Pataskala, OH 43062

740-964-4000
740-927-6017 (fax)

www.redhawkenergy.net
info@redhawkenergy.net

We Specialize In:

- Renewable & "Green" Energy Systems
- Remote Site Power Systems
- Battery Systems, Testers, Monitors & Accessories

Our Products Include:

- Photovoltaic (Solar) Power Systems
- Wind Generators
- Fuel Cells
- Extended Run Engine Generators
- Thermoelectric Generators
- Hybrid Power Systems
- RP Series Retractable Masts
- Retractable Wind Generator Pole Adaptors
- Nickel Cadmium Batteries
- Lead Acid Batteries
- RH Series Portable Battery Testers
- Battery Enclosures & Boxes
- Battery Watering Tools
- Battery Lifting Slings

RedHawk Energy Systems, LLC and Alset Corporation have partnered to offer the Lightning Shield Protection System for remote site applications susceptible to disruptive lightning activity. The Lightning Shield System is a new protection technology that detects imminent lightning activity and preemptively eliminates the potential GPR (Ground Potential Rise) fault path - a high energy ground pulse that breaches the protection of electronic remote sites. Having a Lightning Shield System installed at a lightning prone site will improve the site reliability and significantly reduce its repair costs.

PROBLEM?

Remote electronics sites are particularly exposed to lightning GPR (Ground Potential Rise) in spite of the best convention protection systems such as TVSS. Severe storm tracks and resistive earth (sandy clay, limestone, granite) combine to momentarily saturate grounding systems with high frequency energy. Lightning then creates a path to lower ground through the conductive electronics.

SOLUTION: ALSET LIGHTNING SHIELD

- Detects imminent lightning activity and eliminates the potential fault path through the electronics for the duration of the threat
- Remote management to monitor events and routinely test the site generator or battery plant
- Low cost of ownership; payback in one lightning storm!



LIGHTNING SHIELD

.....WHEN CONVENTIONAL PROTECTION IS NOT ENOUGH

TECHNOLOGY

LIGHTNING SHIELD COMPLETES THE PROTECTION PUZZLE, PROVIDING THE MOST EFFECTIVE PROTECTION FOR REMOTE ELECTRONIC SITES

Lightning energy is not instantly dissipated in the strike area. High voltage gradients (Ground Potential Rise) are propagated across the earth's surface. Grounding systems are designed and measured based on 60Hz AC models, but react inductively to lightning energy that ranges from KHz to MHz.

During lightning GPR fault conditions the grounding system is elevated thousand of volts. Grounding and surge protection conduct in both directions, allowing the elevated voltage on the grounding system to impress high voltage across the equipment, seeking the lower utility ground. This "back door" fault path follows the power circuits through electronics, producing damaging voltage gradients across modules and components.

Lightning Shield detects the impending lightning threat and opens the utility power circuit to eliminate the potential fault path. Opening the AC circuit creates a single point ground condition - the site ground voltage rises and falls with the GPR, but current cannot flow across the open circuit. The lightning energy is forced to dissipate in the site grounding system.

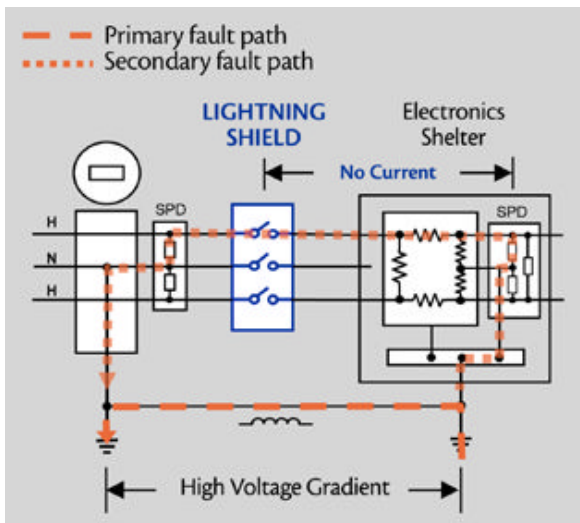

During the protected isolation, operations safely continue on the site battery plant, and AC power is automatically reconnected after the threat passes. The safety ground is always maintained.

Quality surge protection is required to shunt power and telecom transients to the grounding system.

Lightning Shield assures that surge protection does not provide a "reverse" path for elevated voltage on the ground system. Lightning Shield also isolates equipment from 60Hz GPR (down power lines) that is caused by lightning strikes. Lightning Shield provides "back up" protection for severe AC power surges that fatigue and fail the surge protection. Lightning Shield requires AC power to normalize before re-connecting, protecting the electronics from power recovery transients.

Low resistance grounding is required to sink fault current to the earth. Lightning Shield assures the voltage rise during GPR fault conditions does not create differential voltages across the electrical and electronic circuits.

Grounding enhancements may not be effective for lightning energy in resistive earth. A lower ground resistance for 60Hz AC does not significantly reduce the ground impedance to the much higher lightning frequencies. Lightning Shield forces GPR to dissipate in the grounding system, whether it measures 2, 5 or 25 ohms resistance or higher.

LIGHTNING SHIELD SPECS

50 AMP (14" x 14" x 10")

200 AMP (20" x 20" x 15")



LIGHTNING SHIELD AUGMENTS SURGE PROTECTION & GROUND SYSTEMS

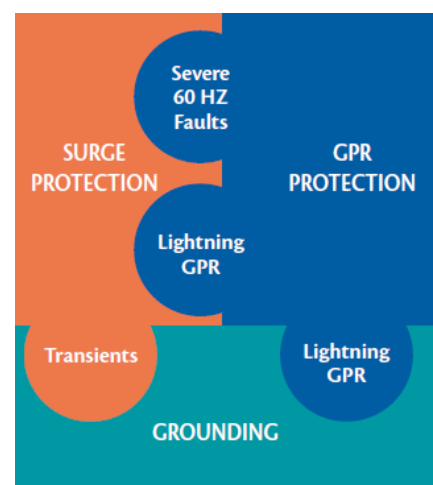

FEATURES & BENEFITS

Lightning Shield responds to significant changes in the electrostatic field - the unique signature of lightning.

PROTECTIVE ISOLATION IS ACTIVATED FOR:

- Lightning formation before an imminent strike
- Lightning GPR from approaching storms
- Power-line flashovers

Lightning Shield incorporates AC surge protection and voltage comparators to monitor AC power.

PROTECTIVE ISOLATION IS ACTIVATED FOR:

- Surges that breach the SPD
- Sags and re-powering transients
- Initial power-up and AC power loss



- Uniquely augments surge protection and grounding systems
- Improves operating efficiencies
- Proven and cost effective solution with short term payback

USER CONTROLS



DETECTION

- Adjust the GPR sensitivity for local conditions
- Adjust the high and low AC voltage

ISOLATION

- Adjust the GPR isolation timer for typical storm conditions
- Synchronize the AC isolation and ATS timers

REMOTE MANAGEMENT



CONFIGURE PROTECTION PARAMETERS, MONITOR, LOG AND DOWNLOAD EVENTS

- GPR & AC faults
- Changes to protection parameters

RUN TESTS

- Battery discharge under load, or generator activation
- GPR simulation

CONFIGURE COMMUNICATIONS AND SECURITY

- POTS/Modem port - dial-up IP
- Ethernet data port - IP and SNMP

COMMON FEATURES

SERVICE	120/240 VAC - 60Hz
POWER CONSUMPTION	30W Connected; 23W Isolated
CONTROLS	Power, Service Bypass; Hi-Low VAC; Isolation Transformers
ALARMS	4 Dry Contact - NC & NO
ENCLOSURES	Controller - NEMA 4X; Detector - Aluminum
STANDARDS COMPLIANCE	UL 60950-1; CSA C22.2

RAILROAD APPLICATIONS

Railway electronics are exposed to lightning which frequently causes damages to rectifiers, control electronics and communication systems. Remote installations are particularly exposed to Lightning Ground Potential Rise (L-GPR) since they have limited grounding infrastructure to dissipate the severe voltage gradients that radiate through the earth's surface.

L-GPR is created by a rapid charge injection into the ground when a lightning ground strike occurs. The soil cannot instantly dissipate the charge, causing a significant voltage increase at the strike point with respect to other locations. The voltage differences across 10 feet can be tens of thousands of volts for 100 microseconds. This sustained potential difference between ground points elevates the ground bar voltage which can overcome the threshold of the bonded surge suppressors. The elevated potential is connected directly to the I/O communication lines and a secondary discharge path is created through the equipment to remote ground.

Soil resistivity has a significant bearing on L-GPR. Resistive soil (sandy, clay, limestone, gravel) inhibits the earth's dissipation of lightning energy; causing a dramatically higher L-GPR. Dehydration of soluble metal compounds (e.g. salt) in the earth has a similar effect - lower conductivity increases the severity and propagation of L-GPR. "Dry lightning" throughout many regions is a prescription for electrical and electronic damage!

Lightning Shield is user configurable. L-GPR sensitivity may be set for local soil and storm conditions. The AC voltage comparator thresholds may be set between 90V and 145V for each phase line. NO/NC relays communicate power status and threat notifications. Two models are available to accommodate breakers rated 50 Amps and 200 Amps.

Visit www.alsetcorp.com for additional information on the Lightning Shield Protection System.



SPECIFICATIONS	LS 50	LS 200
ISOLATION	6kV Impulse <20mSec	10kV Impulse <15mSec
CURRENT CAPACITY	32 FLA, 50 Amp Resistive	115 FLA, 200 Amp Resistive
MTBF - CONTRACTOR	8,000,000 Cycles	15,000,000 Cycles
WIRE GAUGE	14-6 AWG	8-4/0 AWG
SHIPPING FOOTPRINT	10 lbs, 14" x 14" x 10"	45 lbs, 20" x 20" x 15"
RUS LISTING	Lightning Shield - 50 Amp	Lightning Shield - 200 Amp

REDHAWK ENERGY SYSTEMS, LLC
10340 PALMER RD., S.W.
PATASKALA, OH 43062

PH: (740) 964-4000
Fx: (740) 927-6017

Website: www.redhawkenergy.net
Email: info@redhawkenergy.net